



# Product Guide 2010/2011

Gas-fired and solar thermal heating solutions from Worcester, Bosch Group





## Worcester and you. Making a difference.

Worcester, Bosch Group  
Technical Help line

Working together for many years, heating professionals and Worcester have been making a real difference in hundreds of thousands of homes. We are recognised as a market leader in high efficiency, condensing boiler technology and are also committed to providing renewable energy solutions.

As part of the Bosch Group, our products are designed and manufactured to provide the high levels of quality and reliability which are synonymous with the Bosch name throughout the world.

We're a leading British company, employing approximately 1,800 people at our headquarters and manufacturing plants in Worcester and at Clay Cross in Derbyshire, including a nationwide network of over 300 Service Engineers and over 80 technically-trained Field Sales Managers.

As part of Europe's largest supplier of heating products, Worcester, Bosch Group has the resources and support capability to offer you the value-added solutions we feel you deserve.







































“At Worcester we recognise the vital role you, our customer, has in the specification and installation of ‘A’ rated, energy efficient appliances. We will continue to invest in our products, people, facilities and added value services such as training, to give you the support you require in providing a total solution for your customers’ comfort.”

Richard Soper,  
Managing Director, Bosch Thermotechnology

# Contents

SEDBUK gas ratings, solar compatibility & LPG models	5
Did you know?	6 - 7
Flue terminal positioning	8 - 11
Condensing gas-fired boilers	
Wall mounted combi	
Greenstar i Junior	12 - 13
Greenstar Si	14 - 15
Greenstar CDi	16 - 17
Floor standing combi	
Greenstar Highflow CDi	18 - 19
Wall mounted system	
Greenstar i System	20 - 21
Greenstar CDi System	22 - 23
Wall mounted regular	
Greenstar Ri	24 - 25
Greenstar CDi Regular	26 - 27
Floor standing regular	
Greenstar FS CDi Regular	28 - 29
Condensfit II plume management system	30
Flexible flue system	31
Optional plug-in controls	32 - 39
Accessories	
Greenstar wall mounted gas-fired boiler accessories	40 - 41
Solar	
Greenskies solar panels	42 - 51
Greenskies Cylinders	52 - 53
Training	54 - 55
Useful contacts	56 - 57
Other Bosch companies	57
Conversion tables	58 - 59
Consumer & technical literature, CDs & DVDs	60 - 61
Useful numbers	64

# SEDBUK ratings for gas-fired boilers

Appliance	Efficiency rating %*	SEDBUK Band	LPG	Compatible features
Greenstar Highflow 550CDi	90.8	A	•	
Greenstar Highflow 440CDi	90.8	A	•	
Greenstar FS 30CDi Regular	90.5	A	•	 
Greenstar FS 42CDi Regular	90.3	A	•	 
Greenstar 30CDi Regular	90.3	A	•	 
Greenstar 27CDi Combi	90.2	A	•	
Greenstar 40CDi Regular	90.2	A	•	 
Greenstar 24Ri	90.2	A	•	 
Greenstar 24i System	90.2	A	•	 
Greenstar 30CDi Combi	90.2	A	•	
Greenstar 37CDi Combi	90.2	A	•	
Greenstar 42CDi Combi	90.2	A	•	
Greenstar 24i Junior	90.1	A	•	
Greenstar 28i Junior	90.1	A	•	
Greenstar 25Si	90.1	A	•	
Greenstar 30Si	90.1	A	•	
Greenstar 12i System	90.1	A	•	 
Greenstar 15i System	90.1	A	•	 
Greenstar 18i System	90.1	A	•	 
Greenstar 12Ri	90.1	A	•	 
Greenstar 15Ri	90.1	A	•	 
Greenstar 18Ri	90.1	A	•	 
Greenstar 30CDi System	90.3	A	•	 



Compatible with solar



Energy Saving product recommended by the Energy Saving Trust.

Seasonal efficiency is given as the SEDBUK number. The value is used in the UK Government's Standard Assessment Procedure (SAP) for energy rating of dwellings. The test data from which it has been calculated has been certified by a notified body as indicated. \*Natural Gas Ratings shown.

# Did you know?

## Did you know Worcester has a new range of Worcester Greenstar floor standing gas-fired boilers?

- An updated version of the Greenstar Highflow 440 – the Highflow 440CDi – which is now compatible with the same range of controls as the wall mounted Greenstar CDi and Condensfit II flue system and plume management kit.
- A new variant has been added to the Greenstar Highflow range – the Highflow 550CDi which has a DHW flow rate of up to 25 litres per minute – for more details see page 18.
- Joining the Greenstar floor standing range are the FS 30CDi and FS 42CDi Regular (heat only) boilers that are ideal for the replacement market – for more details see page 28.

## Did you know the i System is now available in 15 & 18kW variants?

The introduction of two new models sees the completion of the Greenstar i System range. For more details see page 20.

## Did you know Worcester has a new range of intelligent controls including weather compensation?

- The FX range of controls enhances the efficiency of the Greenstar CDi combi, system gas-fired boilers and Greenskies solar panel systems. For more details see page 36.
- ISM1 – Intelligent Solar Module – enables integration of Greenskies solar installations with an FX control and Greenstar CDi System boiler for optimum efficiency.
- The new FR10 intelligent room thermostat can be used in conjunction with either of Worcester's plug-in time controls, MT10 or DT20, on all Greenstar CDi gas-fired combi and system boilers.
- FX controls are compatible with Greenstar CDi System boilers fitted with the optional integral diverter valve only.

## Did you know installing Worcester Greenstar gas-fired boilers saves you time and money?

- Every Worcester Greenstar gas-fired boiler has a routing channel to allow pipes behind which negates the need for a wall spacing frame, and the time it takes to assemble, saving you time and money.
- Vertical pre-bent piping kits are available for all the Greenstar wall mounted combi and system boilers. They save you up to 50 minutes installation time. The kits include pre-bent pipes and an earth bonding strip. More details including the individual part numbers can be found on pages 40 and 41.
- A below boiler pipe cover can now be purchased to fit all our wall mounted gas boilers. The cover is curved to match the profile of the boiler fascia and is manufactured from white satin finished plastic which can be cut to size. Part number 7 716 192 608.
- Every Worcester Greenstar gas-fired boiler is also available in an LPG boiler variant as standard which saves the time used to carry out a conversion and no analyser is required for installation.

## Did you know Worcester Greenstar condensing gas-fired boilers could reduce your customers' energy bills and reduce their carbon footprint?

- Greenstar CDi combi boilers condense when delivering hot water as well as condensing in central heating mode – more efficient operation – using less gas for the same amount of hot water.
- The Greenstar CDi combi range has a modulating pump which can save up to 30% in running costs compared to a standard efficiency pump.

*Please note: This product guide lists basic details of the Worcester gas-fired and solar water heating product series. More detailed technical information is available in the Technical Specification brochures and Installation, Commissioning and Servicing Instructions for each product type.*

*It is essential that full technical details are considered before final product specification is made.*

*Contact [www.worcester-bosch.co.uk](http://www.worcester-bosch.co.uk) or call 0844 892 9800 to obtain the full technical publications.*

# Flue terminal positioning

## **General position (refer to next page)**

1. The terminal must not cause an obstruction nor the discharge a nuisance. Particular care should be exercised with regards to the plumbing of the flue gases and any increase in noise levels.
2. If a terminal is fitted less than 2 metres above a surface to which people have access, then a guard must be fitted. The terminal guard must be securely fixed to the wall using suitable plugs and corrosion resistant screws. The guard must be symmetrically positioned about the terminal assembly and spaced such that there is a gap of 50mm between the end of the terminal and the guard.
3. In certain weather conditions, a white plume of condensation will be emitted from the flue terminal and siting where this could be a nuisance should be avoided i.e. near security lighting.
4. The air inlet/outlet duct and the terminal of the boiler must not be closer than 25mm to any combustible material. Detailed recommendations on protection of combustible materials are given in BS 5440:1.

The flue system must be installed and terminated in accordance with the recommendations of BS 5440:Part 1.

## **Plume management**

Plume management kits are available for 100mm horizontally terminated flues. Please refer to the installation instructions supplied with the plume management kits.

For more information on Worcester's plume management options, including reduced flue terminal clearances, please read the relevant boiler technical and specification brochure.

# Flue terminal positioning

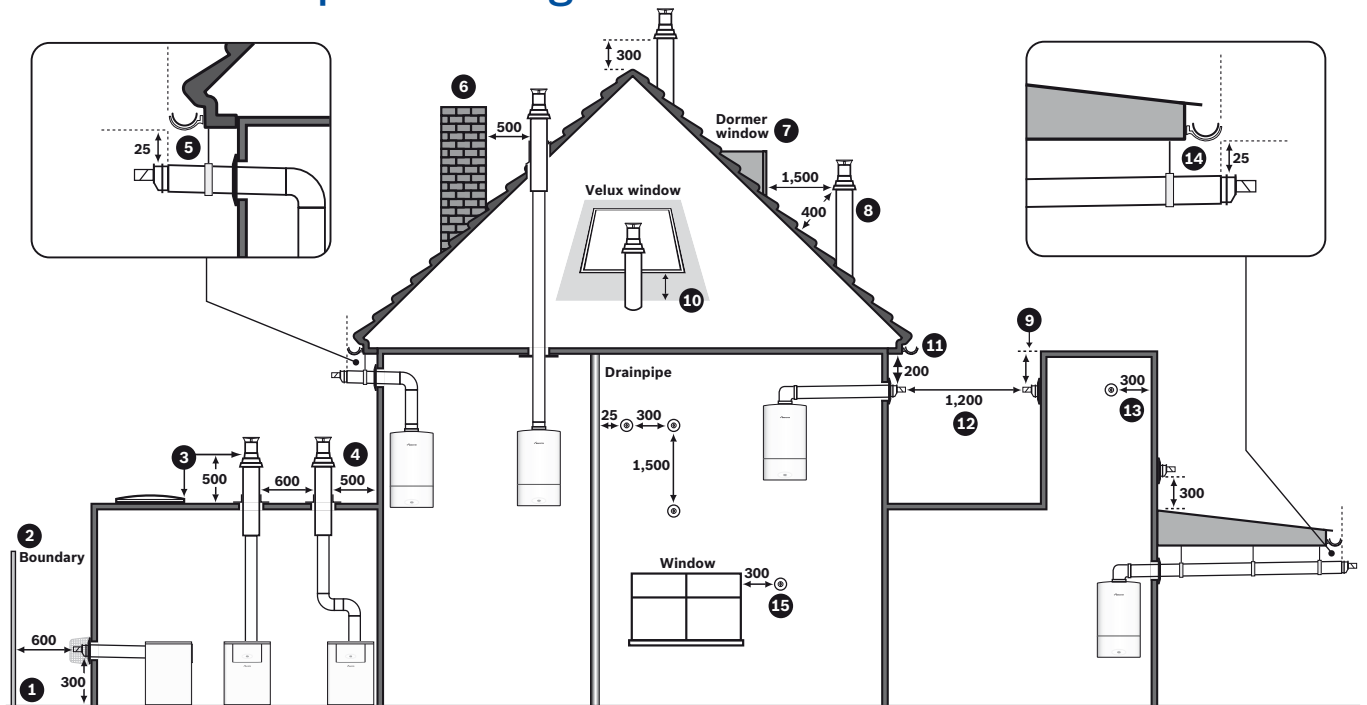

## Note

- All measurements are the minimum clearances required.
- Terminals must be positioned so to avoid combustion products entering the building.
- Support the flue at approximately one metre intervals and at a change of direction, use suitable brackets and fittings (flue bracket part numbers: 100mm – 7 716 191 092, 125mm – 7 716 191 174).

## Key to illustration

1. Flue clearance must be at least 300mm from the ground. Terminal guards must be fitted if the flue is less than 2 metres from the ground or if a person could come into contact with the flue terminal.
2. 600mm distance to a boundary, unless it will cause a nuisance. BS 5440: Part 1 recommends that care is taken when siting terminals in relation to boundaries.
3. 600mm minimum clearance from a skylight to a vertical flue.
4. Vertical flue clearance, 500mm to non-combustible building material, and 1,500mm clearance to combustible building material.

5. The dimension below eaves, gutters, pipes and drains can be reduced to 25mm, as long as the flue terminal is extended to clear any overhang. Any external flue joints must be sealed with a suitable silicon sealant.
6. 500mm clearance to any vertical structure on a roof, 600mm to room sealed flue or 1,500mm to an open flue.
7. 1,500mm between a vertical flue terminal and a window or dormer window.
8. 400mm from a pitched roof or in regions with heavy snow fall 500mm.
9. The flue cannot be lower than 1,000mm from the top of a light well due to the build up of combustion products.
10. 2,000mm below a Velux window, 600mm above or to either side of the Velux window.
11. 200mm below eaves and 75 mm below gutters, pipes & drains.
12. 1,200mm between terminals facing each other.
13. 300mm to an internal or external corner.

## Installations in car ports are not recommended.

14. The dimension below eaves, balconies and car ports can be reduced to 25mm, as long as the flue terminal is extended to clear any overhang. Any external flue joints must be sealed with suitable silicon sealant.
15. 300mm above, below and either side of an opening door, air vent or opening window.



Wall mounted condensing combi boilers

# Greenstar i Junior series

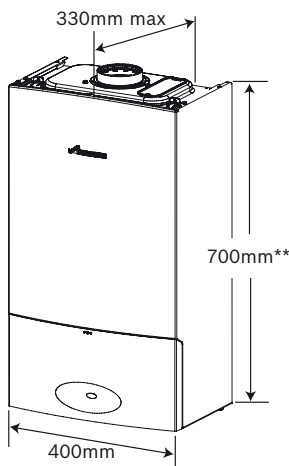

### Clearances

Above flue: 30mm

Left: 5mm

Right: 5mm

Below: 200mm

Front: 20mm\*

\*20mm from a removable cupboard door, 600mm from a fixed surface for servicing. Refer to Tech & Spec for unventilated clearances.

\*\*710mm to top of casing front.

Max DHW output (kW)	Flow rate (l/m)		CH output (kW)	Part no.
	$\Delta T$ 40°C	$\Delta T$ 35°C		
<b>Greenstar 24i Junior</b>				
24	8.6	9.8	7.2 to 24†	<b>NG 7 716 130 141</b> <b>LPG 7 716 130 148</b>
<b>Greenstar 28i Junior</b>				
28	10	11.4	7.2 to 24†	<b>NG 7 716 130 142</b> <b>LPG 7 716 130 147</b>

### Control options

Part no.	Description
<b>Mechanical timers, digital &amp; wireless programmers &amp; room thermostats</b>	
7 716 192 036*	MT10 Mechanical Timer
7 716 192 038	DT20 Twin Channel Digital Programmer
7 716 192 037*	MT10RF Mechanical RF Thermostat
7 716 192 052	DT10RF Digistat
7 716 192 054	DT20RF Digital RF Thermostat with Twin Channel Programmer

†13kW with low NOx code plug fitted.

\*These controls will not provide hot water pre-heat time control.



### Flue lengths

Maximum flue lengths inc. terminal (mm)			
Diameter	Direction	24i Junior	28i Junior
100mm	Horizontal	4,600	4,600
	Vertical	6,400	6,400
125mm	Horizontal	13,000	13,000
	Vertical	15,000	15,000

### Horizontal and vertical fluing options

Components	Part no.	Description
<b>100mm diameter</b>		
	7 716 191 082	Standard telescopic flue & terminal (350 - 570mm)
	7 716 191 171	Long telescopic flue kit (570 - 790mm)
	7 719 002 430	Vertical 1,090mm BF kit (inc. adaptor)
	7 716 191 083	Extension flue kit (960mm)
	7 716 191 172	2m flue extension
	7 716 191 133	Short flue extension (220mm)
	7 716 191 084	90° flue bend
	7 716 191 085	45° flue bend
	7 719 002 432	High level horizontal flue adaptor
	7 716 191 092	Support bracket kit
	7 716 191 173	Support bracket kit (6 pack)
	7 716 191 090	Flashing – flat roof
	7 716 191 091	Flashing – pitched roof
	7 716 191 086	Plume management kit (60mm dia.)
<b>125mm diameter</b>		
	7 719 003 702	Standard telescopic flue & terminal (405 - 600mm)
	7 719 002 431	Vertical 1,365mm BF kit (inc. adaptor)
	7 719 003 666	Extension flue kit (960mm)
	7 719 003 664	90° flue bend
	7 719 003 665	45° flue bend
	7 719 002 433	High level horizontal flue adaptor
	7 716 191 174	Support bracket kit
	7 716 191 090	Flashing – flat roof
	7 716 191 091	Flashing – pitched roof

Note: For every 90° bend deduct 2 metres and 1 metre for every 45° bend. See page 30 for plume management components & accessories



Wall mounted condensing combi boilers

# Greenstar Si series

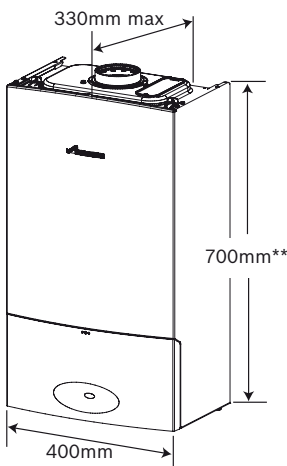

### Clearances

Above flue: 30mm

Left: 5mm

Right: 5mm

Below: 200mm

Front: 20mm\*

\*20mm from a removable cupboard door, 600mm from a fixed surface for servicing. Refer to Tech & Spec for unventilated clearances.

\*\*710mm to top of casing front.

Max DHW output (kW)	Flow rate (l/m)		CH output (kW)	Part no.
	$\Delta T$ 40°C	$\Delta T$ 35°C		
<b>Greenstar 25Si</b>				
25	8.9	10.2	7.2 to 24†	<b>NG 7 716 130 139</b> <b>LPG 7 716 130 146</b>
<b>Greenstar 30Si</b>				
30	10.7	12.3	7.2 to 24†	<b>NG 7 716 130 140</b> <b>LPG 7 716 130 145</b>

### Control options

Part no.	Description
<b>Intelligent controls</b>	
7 716 192 065	FR10 Intelligent Room Thermostat#
7 716 192 066	FR110 Programmable Room Thermostat
7 716 192 067	FW100 Weather Compensation Controller
<b>Mechanical timers, digital &amp; wireless programmers &amp; room thermostats</b>	
7 716 192 036*	MT10 Mechanical Timer
7 716 192 038	DT20 Twin Channel Digital Programmer
7 716 192 037*	MT10RF Mechanical RF Thermostat
7 716 192 052	DT10RF Digistat
7 716 192 053	DT10RF Optimiser
7 716 192 054	DT20RF Digital RF Thermostat with Twin Channel Programmer



### Flue lengths

Maximum flue lengths inc. terminal (mm)			
Diameter	Direction	25Si	30Si
100mm	Horizontal	4,600	4,600
	Vertical	6,400	6,400
125mm	Horizontal	13,000	13,000
	Vertical	15,000	15,000

### Horizontal and vertical fluing options

Components	Part no.	Description
<b>100mm diameter</b>		
	7 716 191 082	Standard telescopic flue & terminal (350 - 570mm)
	7 716 191 171	Long telescopic flue kit (570 - 790mm)
	7 719 002 430	Vertical 1,090mm BF kit (inc. adaptor)
	7 716 191 083	Extension flue kit (960mm)
	7 716 191 172	2m flue extension
	7 716 191 133	Short flue extension (220mm)
	7 716 191 084	90° flue bend
	7 716 191 085	45° flue bend
	7 719 002 432	High level horizontal flue adaptor
	7 716 191 092	Support bracket kit
	7 716 191 173	Support bracket kit (6 pack)
	7 716 191 090	Flashing – flat roof
	7 716 191 091	Flashing – pitched roof
	7 716 191 086	Plume management kit (60mm dia.)
<b>125mm diameter</b>		
	7 719 003 702	Standard telescopic flue & terminal (405 - 600mm)
	7 719 002 431	Vertical 1,365mm BF kit (inc. adaptor)
	7 719 003 666	Extension flue kit (960mm)
	7 719 003 664	90° flue bend
	7 719 003 665	45° flue bend
	7 719 002 433	High level horizontal flue adaptor
	7 716 191 174	Support bracket kit
	7 716 191 090	Flashing – flat roof
	7 716 191 091	Flashing – pitched roof

†13kW with low NOx code plug fitted. #For use with MT10 and DT20 only.

\*These controls will not provide hot water pre-heat time control.

Note: For every 90° bend deduct 2 metres and 1 metre for every 45° bend. See page 30 for plume management components & accessories





Wall mounted condensing combi boilers

# Greenstar CDi series

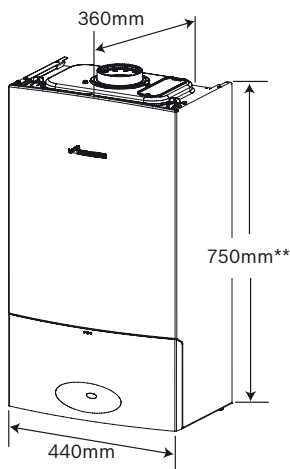

### Clearances

- Above flue: 30mm
- Left: 5mm
- Right: 5mm
- Below: 200mm
- Front: 20mm\*

\*20mm from a removable cupboard door, 600mm from a fixed surface for servicing. Same clearances for ventilated & unventilated compartments.

\*\*760mm to top of casing front.

Max DHW output (kW)	Flow rate (l/m)		CH output (kW)	Part no.
	ΔT 40°C	ΔT 35°C		
<b>Greenstar 27CDi</b>				
27	9.7	11.1	7.7 to 26.2	<b>NG 7 713 331 021</b> <b>LPG 7 713 331 022</b>
<b>Greenstar 30CDi</b>				
30	11.5	13.1	7.7 to 30	<b>NG 7 713 331 023</b> <b>LPG 7 713 331 024</b>
<b>Greenstar 37CDi</b>				
37	13.3	15.2	9.4 to 30	<b>NG 7 713 331 017</b> <b>LPG 7 713 331 018</b>
<b>Greenstar 42CDi</b>				
42	15.1	17.2	9.4 to 30	<b>NG 7 713 331 019</b> <b>LPG 7 713 331 020</b>

### Control options

Part no.	Description
<b>Intelligent controls</b>	
7 716 192 065	FR10 Intelligent Room Thermostat#
7 716 192 066	FR110 Programmable Room Thermostat
7 716 192 067	FW100 Weather Compensation Controller
7 719 002 505*	RT10 Room Thermostat
7 719 002 506	TD200 Text Display
<b>Mechanical timers, digital &amp; wireless programmers &amp; room thermostats</b>	
7 716 192 036**	MT10 Mechanical Timer
7 716 192 038	DT20 Twin Channel Digital Programmer
7 716 192 037**	MT10RF Mechanical RF Thermostat
7 716 192 052	DT10RF Digistat
7 716 192 053	DT10RF Optimiser
7 716 192 054	DT20RF Digital RF Thermostat with Twin Channel Programmer

#For use with MT10 and DT20 only. \*Must be used with TD200.  
\*\*These controls will not provide hot water pre-heat time control.



### Flue lengths

Maximum flue lengths inc. terminal (mm)					
Diameter	Direction	27CDi	30CDi	37CDi	42CDi
100mm	Horizontal	10,000	7,000	6,500	6,000
	Vertical	11,500	8,000	8,000	7,500
125mm	Horizontal	23,000	16,000	16,000	12,000
	Vertical	23,000	16,000	16,000	16,000

### Horizontal and vertical fluing options

Components	Part no.	Description
<b>100mm diameter</b>		
	7 716 191 082	Standard telescopic flue & terminal (350 - 570mm)
	7 716 191 171	Long telescopic flue kit (570 - 790mm)
	7 719 002 430	Vertical 1,090mm BF kit (inc. adaptor)
	7 716 191 083	Extension flue kit (960mm)
	7 716 191 172	2m flue extension
	7 716 191 133	Short flue extension (220mm)
	7 716 191 084	90° flue bend
	7 716 191 085	45° flue bend
	7 719 002 432	High level horizontal flue adaptor
	7 716 191 092	Support bracket kit
	7 716 191 173	Support bracket kit (6 pack)
	7 716 191 090	Flashing – flat roof
	7 716 191 091	Flashing – pitched roof
	7 716 191 086	Plume management kit (60mm dia.)

Note: 60/100mm - for every 90° bend deduct 1.5 metres and 0.75 metres for every 45° bend.

<b>125mm diameter</b>		
	7 719 003 702	Standard telescopic flue & terminal (405 - 600mm)
	7 719 002 431	Vertical 1,365mm BF kit (inc. adaptor)
	7 719 003 666	Extension flue kit (960mm)
	7 719 003 664	90° flue bend
	7 719 003 665	45° flue bend
	7 719 002 433	High level horizontal flue adaptor
	7 716 191 174	Support bracket kit
	7 716 191 090	Flashing – flat roof
	7 716 191 091	Flashing – pitched roof

Note: 80/125mm - for every 90° bend deduct 2 metres and 1 metre for every 45° bend.

See page 30 for plume management components & accessories



Floor standing condensing combi boilers

# Greenstar Highflow CDi series

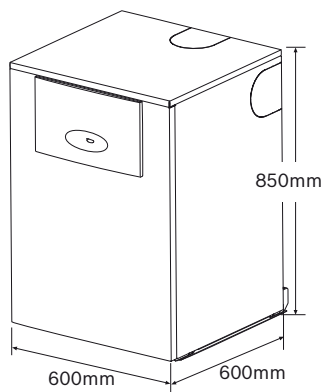

### Clearances

Above:	15mm
Left:	5mm
Right:	5mm
Front:	25mm*

\*600mm required for servicing.  
Refer to Tech & Spec for unventilated clearances.

Max DHW output (kW)	Flow rate (l/m) ΔT 35°C	CH output (kW)	Part no.
<b>Greenstar Highflow 440CDi</b>			
29.5	20	7.4 to 29.2	<b>NG 7 715 330 041</b> <b>LPG 7 715 330 053</b>
<b>Greenstar Highflow 550CDi</b>			
41.1	25	9.7 to 30.6	<b>NG 7 715 330 040</b> <b>LPG 7 715 330 052</b>

### Control options

Part no.	Description
<b>Intelligent controls</b>	
7 716 192 065	FR10 Intelligent Room Thermostat#
7 716 192 066	FR110 Programmable Room Thermostat
7 716 192 067	FW100 Weather Compensation Controller
7 719 002 505†	RT10 Room Thermostat
7 719 002 506	TD200 Text Display
<b>Mechanical timers, digital &amp; wireless programmers &amp; room thermostats</b>	
7 716 192 036**	MT10 Mechanical Timer
7 716 192 038	DT20 Twin Channel Digital Programmer
7 716 192 037**	MT10RF Mechanical RF Thermostat
7 716 192 052	DT10RF Digistat
7 716 192 053	DT10RF Optimiser
7 716 192 054	DT20RF Digital RF Thermostat with Twin Channel Programmer

### Flue lengths



Maximum flue lengths inc. terminal (mm)			
Diameter	Direction	Highflow 440CDi	Highflow 550CDi
100mm	Horizontal	4,000	4,000
	Vertical	6,400	6,400
125mm	Horizontal	13,000	13,000
	Vertical	15,000	15,000

### Horizontal and vertical fluing options

Components	Part no.	Description
<b>100mm diameter</b>		
	7 716 191 155	Standard telescopic flue kit (310 - 530mm)
	7 716 191 156	Vertical 1,140mm BF kit (inc. adaptor)
	7 716 191 083	Extension flue kit (960mm)
	7 716 191 172	2m flue extension
	7 716 191 133	Short flue extension (220mm)
	7 716 191 084	90° flue bend
	7 716 191 085	45° flue bend
	7 716 191 164	Vertical flue adaptor
	7 716 191 092	Support bracket kit
	7 716 191 173	Support bracket kit (6 pack)
	7 716 191 090	Flashing – flat roof
	7 716 191 091	Flashing – pitched roof
	7 716 191 086	Plume management kit (60mm dia.)

Note: 60/100mm - for every 90° bend deduct 1.5 metres and 0.75 metres for every 45° bend.

<b>125mm diameter</b>		
	7 716 191 157	Standard horizontal flue kit (965mm)
	7 716 191 158	Vertical 1,365mm BF kit (inc. adaptor)
	7 719 003 666	Extension flue kit (960mm)
	7 719 003 664	90° flue bend
	7 719 003 665	45° flue bend
	7 716 191 165	Vertical flue adaptor
	7 716 191 174	Support bracket kit
	7 716 191 090	Flashing – flat roof
	7 716 191 091	Flashing – pitched roof

Note: 80/125mm - for every 90° bend deduct 2 metres and 1 metre for every 45° bend.

# Greenstar i System series

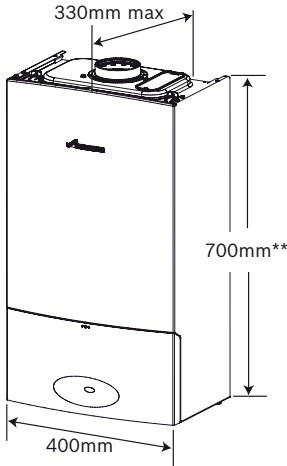

### Clearances

Above flue: 30mm

Left: 5mm

Right: 5mm

Below: 200mm

Front: 20mm\*

\*20mm from a removable cupboard door, 600mm from a fixed surface for servicing. Refer to Tech & Spec for unventilated clearances.

\*\*710mm to top of casing front.

CH output (kW)	Part no.
<b>Greenstar 12i System</b>	
4 to 12	<b>NG 7 716 130 143</b> <b>LPG 7 716 130 150</b>
<b>Greenstar 15i System</b>	
5 to 15	<b>NG 7 716 130 168</b> <b>LPG 7 716 130 169</b>
<b>Greenstar 18i System</b>	
6 to 18	<b>NG 7 716 130 170</b> <b>LPG 7 716 130 171</b>
<b>Greenstar 24i System</b>	
7.2 to 24	<b>NG 7 716 130 144</b> <b>LPG 7 716 130 149</b>

System boilers using a Worcester plug-in controller must have the optional diverter valve kit fitted. It is incompatible with Y or S plan systems.

### Control options

Part no.	Description
<b>Intelligent controls</b>	
7 716 192 065	FR10 Intelligent Room Thermostat#
7 716 192 066	FR110 Programmable Room Thermostat
7 716 192 067	FW100 Weather Compensation Controller
7 716 192 068	ISM1 Intelligent Solar Module
<b>Digital &amp; wireless programmers &amp; room thermostats</b>	
7 716 192 038	DT20 Twin Channel Digital Programmer
7 716 192 052	DT10RF Digistat
7 716 192 054	DT20RF Digital RF Thermostat with Twin Channel Programmer
7 716 192 566	Optional Diverter Valve Kit – 12kW
7 716 192 567	Optional Diverter Valve Kit – 15kW
7 716 192 568	Optional Diverter Valve Kit – 18kW
7 716 192 409	Optional Diverter Valve Kit – 24kW

#Must be used with DT20.



### Flue lengths



Maximum flue lengths inc. terminal (mm)					
Diameter	Direction	12i System	15i System	18i System	24i System
100mm	Horizontal	4,600	4,600	4,600	4,600
	Vertical	6,400	6,400	6,400	6,400
125mm	Horizontal	13,000	13,000	13,000	13,000
	Vertical	15,000	15,000	15,000	15,000

### Horizontal and vertical fluing options

Components	Part no.	Description
<b>100mm diameter</b>		
	7 716 191 082	Standard telescopic flue & terminal (350 - 570mm)
	7 716 191 171	Long telescopic flue kit (570 - 790mm)
	7 719 002 430	Vertical 1,090mm BF kit (inc. adaptor)
	7 716 191 083	Extension flue kit (960mm)
	7 716 191 172	2m flue extension
	7 716 191 133	Short flue extension (220mm)
	7 716 191 084	90° flue bend
	7 716 191 085	45° flue bend
	7 719 002 432	High level horizontal flue adaptor
	7 716 191 092	Support bracket kit
	7 716 191 173	Support bracket kit (6 pack)
	7 716 191 090	Flashing – flat roof
	7 716 191 091	Flashing – pitched roof
	7 716 191 086	Plume management kit (60mm dia.)

<b>125mm diameter</b>		
	7 719 003 702	Standard telescopic flue & terminal (405 - 600mm)
	7 719 002 431	Vertical 1,365mm BF kit (inc. adaptor)
	7 719 003 666	Extension flue kit (960mm)
	7 719 003 664	90° flue bend
	7 719 003 665	45° flue bend
	7 719 002 433	High level horizontal flue adaptor
	7 716 191 174	Support bracket kit
	7 716 191 090	Flashing – flat roof
	7 716 191 091	Flashing – pitched roof

Note: For every 90° bend deduct 2 metres and 1 metre for every 45° bend. See page 30 for plume management components & accessories

# Greenstar 30CDi System

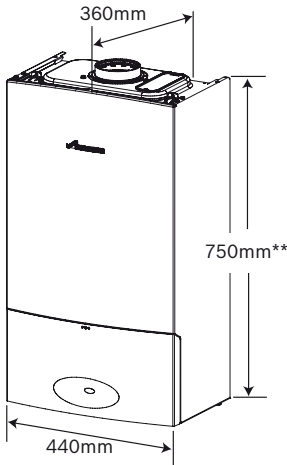

## Clearances

Above flue: 30mm

Left: 5mm

Right: 5mm

Below: 200mm

Front: 20mm\*

\*20mm from a removable cupboard door, 600mm from a fixed surface for servicing. Same clearances for ventilated & unventilated compartments.

\*\*760mm to top of casing front.

CH output (kW)	Part no.
Greenstar 30CDi System	
7.7 to 30	<b>NG 7 712 331 893</b> <b>LPG 7 712 331 888</b>

System boilers using a Worcester plug-in controller must have the optional diverter valve kit fitted. It is incompatible with Y or S plan systems.

## Control options

Part no.	Description
<b>Intelligent controls</b>	
7 716 192 065	FR10 Intelligent Room Thermostat#
7 716 192 066	FR110 Programmable Room Thermostat
7 716 192 067	FW100 Weather Compensation Controller
7 716 192 068	ISM1 Intelligent Solar Module
7 719 002 824	Intelligent System Package
<b>Digital &amp; wireless programmers &amp; room thermostats</b>	
7 716 192 038	DT20 Twin Channel Digital Programmer
7 716 192 052	DT10RF Digistat
7 716 192 053	DT10RF Optimiser
7 716 192 054	DT20RF Digital RF Thermostat with Twin Channel Programmer
7 719 002 746	Optional Diverter Valve Kit



## Flue lengths

Maximum flue lengths inc. terminal (mm)		
Diameter	Direction	30CDi System
100mm	Horizontal	7,900
	Vertical	9,400
125mm	Horizontal	18,500
	Vertical	18,500

## Horizontal and vertical fluing options

Components	Part no.	Description
<b>100mm diameter</b>		
	7 716 191 082	Standard telescopic flue & terminal (350 - 570mm)
	7 716 191 171	Long telescopic flue kit (570 - 790mm)
	7 719 002 430	Vertical 1,090mm BF kit (inc. adaptor)
	7 716 191 083	Extension flue kit (960mm)
	7 716 191 172	2m flue extension
	7 716 191 133	Short flue extension (220mm)
	7 716 191 084	90° flue bend
	7 716 191 085	45° flue bend
	7 719 002 432	High level horizontal flue adaptor
	7 716 191 092	Support bracket kit
	7 716 191 173	Support bracket kit (6 pack)
	7 716 191 090	Flashing – flat roof
	7 716 191 091	Flashing – pitched roof
	7 716 191 086	Plume management kit (60mm dia.)

Note: 60/100mm - for every 90° bend deduct 1.5 metres and 0.75 metres for every 45° bend.

125mm diameter		
	7 719 003 702	Standard telescopic flue & terminal (405 - 600mm)
	7 719 002 431	Vertical 1,365mm BF kit (inc. adaptor)
	7 719 003 666	Extension flue kit (960mm)
	7 719 003 664	90° flue bend
	7 719 003 665	45° flue bend
	7 719 002 433	High level horizontal flue adaptor
	7 716 191 174	Support bracket kit
	7 716 191 090	Flashing – flat roof
	7 716 191 091	Flashing – pitched roof

Note: 80/125mm - for every 90° bend deduct 2 metres and 1 metre for every 45° bend.

See page 30 for plume management components & accessories

## Greenstar Ri series

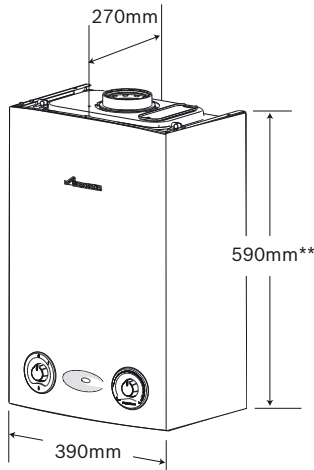

### Clearances

Above flue: 30mm

Left: 5mm

Right: 5mm

Below: 200mm

Front: 20mm\*

\*20mm from a removable cupboard door, 600mm from a fixed surface for servicing. Refer to Tech & Spec for unventilated clearances.

\*\*600mm to top of casing front.

CH output (kW)	Part no.
<b>Greenstar 12Ri</b>	
4 to 12	<b>NG 7 716 130 137</b> <b>LPG 7 716 130 151</b>
<b>Greenstar 15Ri</b>	
5 to 15	<b>NG 7 716 130 153</b> <b>LPG 7 716 130 154</b>
<b>Greenstar 18Ri</b>	
6 to 18	<b>NG 7 716 130 155</b> <b>LPG 7 716 130 156</b>
<b>Greenstar 24Ri</b>	
8 to 24	<b>NG 7 716 130 138</b> <b>LPG 7 716 130 152</b>

### Control options

No Worcester controls are available for regular boilers.

External controls must be used.



### Flue lengths

Maximum flue lengths inc. terminal (mm)					
Diameter	Direction	12Ri	15Ri	18Ri	24Ri
100mm	Horizontal	4,600	4,600	4,600	4,600
	Vertical	6,400	6,400	6,400	6,400
125mm	Horizontal	13,000	13,000	13,000	13,000
	Vertical	15,000	15,000	15,000	15,000

### Horizontal and vertical fluing options

Components	Part no.	Description
<b>100mm diameter</b>		
	7 716 191 082	Standard telescopic flue & terminal (350 - 570mm)
	7 716 191 171	Long telescopic flue kit (570 - 790mm)
	7 719 002 430	Vertical 1,090mm BF kit (inc. adaptor)
	7 716 191 083	Extension flue kit (960mm)
	7 716 191 172	2m flue extension
	7 716 191 133	Short flue extension (220mm)
	7 716 191 084	90° flue bend
	7 716 191 085	45° flue bend
	7 719 002 432	High level horizontal flue adaptor
	7 716 191 092	Support bracket kit
	7 716 191 173	Support bracket kit (6 pack)
	7 716 191 090	Flashing - flat roof
	7 716 191 091	Flashing - pitched roof
	7 716 191 086	Plume management kit (60mm dia.)

<b>125mm diameter</b>		
	7 719 003 702	Standard telescopic flue & terminal (405 - 600mm)
	7 719 002 431	Vertical 1,365mm BF kit (inc. adaptor)
	7 719 003 666	Extension flue kit (960mm)
	7 719 003 664	90° flue bend
	7 719 003 665	45° flue bend
	7 719 002 433	High level horizontal flue adaptor
	7 716 191 174	Support bracket kit
	7 716 191 090	Flashing - flat roof
	7 716 191 091	Flashing - pitched roof

Note: For every 90° bend deduct 2 metres and 1 metre for every 45° bend. See page 30 for plume management components & accessories

## Greenstar CDi Regular series

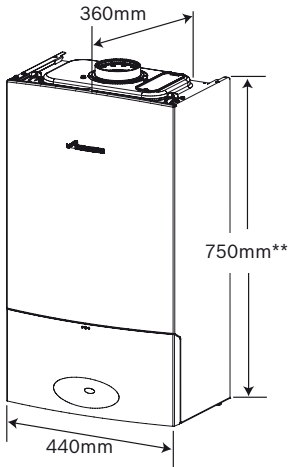

### Clearances

Above flue: 30mm

Left: 5mm

Right: 5mm

Below: 200mm

Front: 20mm\*

\*20mm from a removable cupboard door, 600mm from a fixed surface for servicing. Same clearances for ventilated & unventilated compartments.

\*\*760mm to top of casing front.

CH output (kW)	Part no.
<b>Greenstar 30CDi Regular</b>	
7.7 to 30	<b>NG 7 712 331 895</b> <b>LPG 7 712 331 891</b>
<b>Greenstar 40CDi Regular</b>	
9.4 to 40.8	<b>NG 7 712 231 636</b> <b>LPG 7 712 331 890</b>

### Control options

No Worcester controls are available for regular boilers. External controls must be used.



### Flue lengths

Maximum flue lengths inc. terminal (mm)			
Diameter	Direction	30CDi Regular	40CDi Regular
100mm	Horizontal	7,900	6,000
	Vertical	9,400	7,500
125mm	Horizontal	18,500	12,500
	Vertical	18,500	16,000

### Horizontal and vertical fluing options

Components	Part no.	Description
<b>100mm diameter</b>		
	7 716 191 082	Standard telescopic flue & terminal (350 - 570mm)
	7 716 191 171	Long telescopic flue kit (570 - 790mm)
	7 719 002 430	Vertical 1,090mm BF kit (inc. adaptor)
	7 716 191 083	Extension flue kit (960mm)
	7 716 191 172	2m flue extension
	7 716 191 133	Short flue extension (220mm)
	7 716 191 084	90° flue bend
	7 716 191 085	45° flue bend
	7 719 002 432	High level horizontal flue adaptor
	7 716 191 092	Support bracket kit
	7 716 191 173	Support bracket kit (6 pack)
	7 716 191 090	Flashing - flat roof
	7 716 191 091	Flashing - pitched roof
	7 716 191 086	Plume management kit (60mm dia.)

Note: 60/100mm - for every 90° bend deduct 1.5 metres and 0.75 metres for every 45° bend.

125mm diameter		
	7 719 003 702	Standard telescopic flue & terminal (405 - 600mm)
	7 719 002 431	Vertical 1,365mm BF kit (inc. adaptor)
	7 719 003 666	Extension flue kit (960mm)
	7 719 003 664	90° flue bend
	7 719 003 665	45° flue bend
	7 719 002 433	High level horizontal flue adaptor
	7 716 191 174	Support bracket kit
	7 716 191 090	Flashing - flat roof
	7 716 191 091	Flashing - pitched roof

Note: 80/125mm - for every 90° bend deduct 2 metres and 1 metre for every 45° bend.

See page 30 for plume management components & accessories

## Greenstar FS CDi Regular series

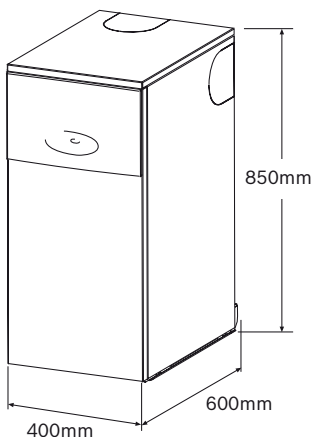

### Clearances

Above:	15mm
Left:	5mm
Right:	5mm
Front:	25mm*

\*600mm to a removable door for servicing. Refer to Tech & Spec for unventilated clearances.

CH output (kW)	Part no.
<b>Greenstar FS 30CDi Regular</b>	
7.7 to 30	<b>NG 7 715 430 442</b> <b>LPG 7 715 430 450</b>
<b>Greenstar FS 42CDi Regular</b>	
9.6 to 40.8	<b>NG 7 715 430 441</b> <b>LPG 7 715 430 451</b>

### Control options

No Worcester controls are available for regular boilers. External controls must be used.

### Flexible flue system compatibility

Compatible with 80mm flexible flue system for fluing through an existing brick chimney.

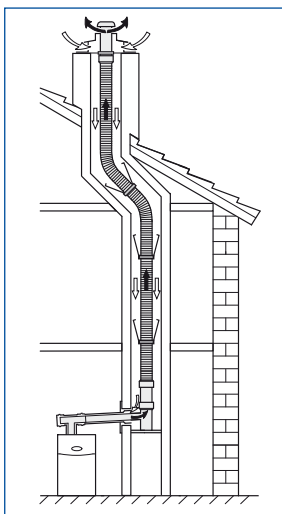

See page 31 for flexible flue system components



### Flue lengths



Maximum flue lengths inc. terminal (mm)			
Diameter	Direction	FS 30CDi Regular	FS 42CDi Regular
100mm	Horizontal	4,000	4,000
	Vertical	6,400	6,400
125mm	Horizontal	13,000	13,000
	Vertical	15,000	15,000

### Horizontal and vertical fluing options

Components	Part no.	Description
<b>100mm diameter</b>		
	7 716 191 155	Standard telescopic flue kit (310 - 530mm)
	7 716 191 156	Vertical 1,140mm BF kit (inc. adaptor)
	7 716 191 083	Extension flue kit (960mm)
	7 716 191 172	2m flue extension
	7 716 191 133	Short flue extension (220mm)
	7 716 191 084	90° flue bend
	7 716 191 085	45° flue bend
	7 716 191 164	Vertical flue adaptor
	7 716 191 092	Support bracket kit
	7 716 191 173	Support bracket kit (6 pack)
	7 716 191 090	Flashing – flat roof
	7 716 191 091	Flashing – pitched roof
	7 716 191 086	Plume management kit (60mm dia.)

Note: 60/100mm - for every 90° bend deduct 1.5 metres and 0.75 metres for every 45° bend.

<b>125mm diameter</b>		
	7 716 191 157	Standard horizontal flue kit (965mm)
	7 716 191 158	Vertical 1,365mm BF kit (inc. adaptor)
	7 719 003 666	Extension flue kit (960mm)
	7 719 003 664	90° flue bend
	7 719 003 665	45° flue bend
	7 716 191 165	Vertical flue adaptor
	7 716 191 174	Support bracket kit
	7 716 191 090	Flashing – flat roof
	7 716 191 091	Flashing – pitched roof
	7 716 191 159	80mm flexible flue system (12m)

Note: 80/125mm - for every 90° bend deduct 2 metres and 1 metre for every 45° bend.

See page 30 for plume management components & accessories

## Condensfit II plume management system

### Part numbers

#### 60mm dia. plume management kit

Comprises:

- 1 x terminal bend
- 1 x extension 500mm
- 1 x outlet assembly
- 1 x clamp pack

**7 716 191 086**

### Accessories



Components	Part no.	Description
<b>60mm diameter</b>		
	7 716 191 086	Plume management kit (60mm dia.)
	7 716 191 087	Extension (1,000mm) kit
	7 716 191 088	90° Bend
	7 716 191 089	45° Bend (pair)
	7 716 191 176	Plume management terminal guard round

For more information refer to the relevant boiler Tech & Spec

## Flexible flue system –

for Greenstar FS CDi Regular models only

### Part numbers

#### 80mm flexible flue system (12m length – can be cut down to suit)

Comprises:

- 1 x flue terminal (A)
- 1 x chimney cowl (B)
- 1 x self-adhesive weather seal (C)
- 1 x terminal adaptor (D)
- 1 x support bracket assembly (E)
- 2 x liner (F)
- 2 x seal (G)
- 1 x flexible liner (H)
- 4 x centralising spacers (I)
- 1 x support bend adaptor (J)
- 1 x support bend (K)
- 1 x bend support (L)
- 2 x flue inspection plates (M)
- 1 x seal for flue inspection plates (N)
- 1 x 125mm flue extension (O)
- 1 x tee piece (P)
- 1 x 125mm flue connector (Q)
- 1 x 80/80mm flue adaptor (R)

**7 716 191 159**

For more information refer to Greenstar FS CDi Regular Tech & Spec  
Part number: 8 716 115 422

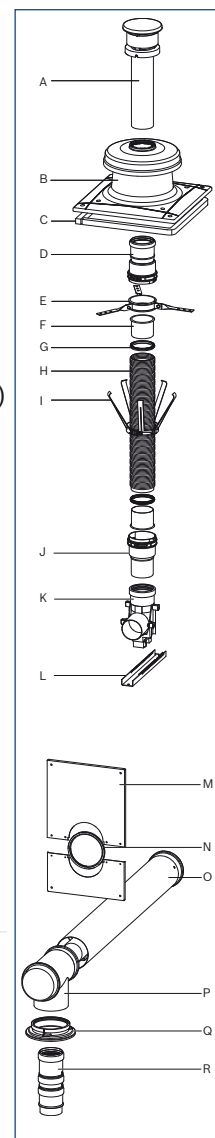



## Optional plug-in controls

There are a number of comprehensive, easy-to-use controls for Greenstar gas-fired boilers. All fascia mounted controls have a simple plug-in connection to the boiler circuit board.

### Mechanical timers

#### **MT10 mechanical timer**



The simplest Worcester control device – an easy-to-use analogue clock for setting heating time periods. It plugs into the boiler fascia via a pre-prepared plug and socket.

#### **MT10RF mechanical RF thermostat**



Has an analogue display for setting comfort and economy time periods and temperature. The receiver plugs into the boiler and is activated remotely by the RF (radio frequency) controller, which requires no wiring. So installation is clean and simple – no disturbance to floorboards or carpets. Nor is there any need for a separate room thermostat.

### Increased SAP ratings

As well as achieving very high SAP ratings for dwellings, the addition of the optimising temperature controller further increases these ratings as well as being part of the recommended best practice, as covered by the CHES design standard.

### Digital and wireless programmers and room thermostats

#### **DT20RF digital RF thermostat with twin channel programmer**



As with the DT20, this features convenient automatic set-up and is very simple to operate.

The timer plugs into the

boiler and offers up to 3 different time periods a day, with the room thermostat (no separate thermostat required) providing the temperature control. This device also has all the no-wiring benefits of the MT10RF. Twin-channel function: when used with a Greenstar condensing system boiler, the second channel gives you 3 time periods for hot water. If used with a Greenstar condensing combi boiler, it times the pre-heat function.

#### **DT20 twin channel digital programmer**



Plugs into the boiler fascia panel and sets automatically to current time, date and day, and adjusts automatically as appropriate in line with British summer time. There are

3 separate time periods for both heating and hot water. Use either the built in pre-set programmes, or choose your own settings.



### ***DT10RF digistat***



A 24-hour programmable room thermostat (which means your time settings remain the same for every day), with the ability to set different temperatures for up to 6 different time periods. No separate room thermostat is required and all the major benefits of no wiring apply. This also helps you to comply with Buildings Regulations Best Practice, as programmable room thermostats can make even further savings over more traditional room thermostats and timers.

### ***DT10RF optimiser***



A sophisticated energy-saving device with the same features as the DT10RF digistat, also featuring optimum start, calculates when it needs to fire the boiler to precisely achieve the required temperature at the required time each day. You can set different temperatures for up to 6 different time periods for each day of the week individually. As an RF (radio frequency) device it has the additional benefits of no wiring required. Nor is a separate thermostat necessary.

### ***TD200 text display***



The TD200 is an advanced plug-in 7-day programmer which features automatic summer-time/winter-time changeover, and full easy-to-use text display (backlight for low light conditions) which provides more information than standard digital controls. You can set 3 on-off periods per day and the programmer's effectiveness is further enhanced by the RT10 room thermostat which gives optimum room temperature control. The digital display shows both the current and your desired (set) temperature. An advance button allows you to move on to the TD200's next heating switch point. An optional wall-mounting socket is available, enabling the TD200 to be positioned away from the boiler if required.

### ***RT10 room thermostat***



A hard wired optimising room temperature controller with digital display for use with the TD200 (above). The display shows current and desired temperature and an advance button allows the user to move to the next heating switch point on the TD200.

### ***TD200 wall mounting socket***



A Worcester branded wall mounting socket which allows the TD200 to be hard wired away from the boiler.

## Intelligent controls

**(compatible with Greenstar CDi Combi and System models only)\***

### FR10 intelligent room thermostat



The FR10 is an intelligent room thermostat that enables load compensation and will offer around 11% energy savings compared to standard on/off controls. The

FR10's load compensation feature means that, rather than just switching the boiler on and off, it will adjust the flow temperature of the central heating water in line with set heating temperature requirements. The smaller the difference between the actual temperature and the set-point temperature, the lower the flow temperature from the boiler.

### FR110 programmable room thermostat



The FR110 is an intelligent programmable room thermostat that enables load compensation for heating and time control of hot water systems. It works in much the

same way as the FR10 but with the added benefit of built-in programming so there is no need for a separate programmer. The controller provides the choice of six weekly heating programmes, with six switching points per day. It also offers a weekly hot water programme with six switching points per day. The six switching points can be used to switch preheat on where the hot water will be delivered to the tap quickly, and energy saving economy mode where the preheat function is turned off.

### FW100 weather compensation controller



The FW100 is a weather compensation controller that enables the boiler to anticipate changes in heating demand in relation

to external temperatures. It comprises a programmable indoor unit to control the boiler and an external sensor located on a north facing wall. The indoor unit can be mounted on the fascia of the boiler using its simple plug-in connection, or wall-mounted remotely. The FW100 combines the functions of room thermostat and programmer and incorporates factory-set heat curves for use with radiators, underfloor heating and fan convectors, making commissioning very straightforward. The units also include a manual override for the user to boost or reduce heating if and when required.

### ISM1 intelligent solar module



The ISM1 is a specially designed interface that integrates a solar heating system with a solar-compatible weather or load compensation unit such as the FW100 or FR110.

As such, it enables the hot water system to take heat from the solar panels whenever direct or even diffused sunlight is available and then bring the boiler back on when there is not enough sunlight available. In this way, the user gets maximum benefit from solar heating while ensuring that hot water is always available.

# Greenstar controls matrix

		Gas-fired boilers					
		COMBI				SYSTEM*	
Control		i-Junior	Si	CDi	Highflow CDi	i-System	CDi System
<b>Mechanical timers</b>	<b>Part no.</b>						
MT10 mechanical timer	7 716 192 036	•	•	•	•		
MT10RF mechanical thermostat	7 716 192 037	•	•	•	•		
<b>Digital and wireless programmers and room thermostats</b>							
DT20 twin channel digital timer	7 716 192 038	•	•	•	•	•	•
DT20RF digital RF thermostat with twin channel programmer	7 716 192 054	•	•	•	•	•	•
DT10RF digistat	7 716 192 052	•	•	•	•	•	•
DT10RF optimiser	7 716 192 053		•	•	•		•
TD200 text display	7 719 002 506			•	•		
RT10 room thermostat	7 719 002 505			•	•		
Intelligent system package	7 719 002 824						•
<b>New intelligent programmers</b>							
FR10 intelligent room thermostat	7 716 192 065		•	•	•	•	•
FR110 programmable room thermostat	7 716 192 066		•	•	•	•	•
FW100 weather compensation controller	7 716 192 067		•	•	•	•	•
ISM1 intelligent solar module	7 716 192 068					•	•

# Greenstar wall mounted gas-fired boiler accessories

## Vertical pre-piping assembly kits



## Vertical Pre-piping Assembly Kits

We are already the only manufacturer whose designs enable pipework to be run behind the boiler as standard and we're taking this feature a step further with our Pre-piping Assembly Kits. The pre-bent pipes have swaged ends for easy soldering and will save you approximately 30 minutes on installation time.

The kits contain:

- 22mm CH flow pipe
- 22mm CH return pipe
- 15mm Mains water inlet pipe\*
- 15mm DHW outlet pipe\*
- 22mm Gas inlet pipe
- Earth bonding strip

Pre-piping Assembly Kits are designed for Greenstar i Junior, Si, CDi, i System and CDi System boilers.

## Earth Bonding Strip

Available as part of the kits and also separately, this not only looks neater, but saves up to 20 minutes on installation compared with fitting separate earth bonding tags to each pipe. It can be used with all Greenstar wall mounted gas-fired boilers.



## Below Boiler Pipe Cover



Suitable for use with all Greenstar wall-hung appliances, this is a neat and simple solution for hiding the pipes on installations where they run below the boiler. The cover is curved to match the profile of the boiler fascia and is manufactured from white satin finished plastic. The cover comes in a 600mm height and can be cut to suit.

## Accessories

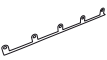
Part no.	Description
<b>Greenstar i Junior &amp; Greenstar Si</b>	
7 716 192 570	Vertical pre-piping assembly kit
<b>Greenstar CDi combi</b>	
7 716 192 607	Vertical pre-piping assembly kit
<b>Greenstar i System</b>	
7 716 192 650	Vertical pre-piping assembly kit
<b>Greenstar CDi System</b>	
7 716 192 651	Vertical pre-piping assembly kit

	Part no.	Description
	7 716 192 686	Earth bonding strip
	7 716 192 608	Below boiler pipe cover (600mm)

# Greenskies solar panels

## Greenskies FKC-1S

90mm 1,145mm

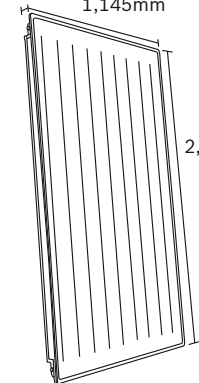

2,070mm

## Greenskies FKC-1W

1,145mm

2,070mm

90mm

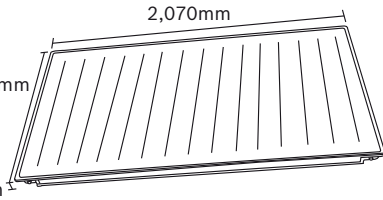

Orientation	Efficiency (%)		Surface area (m <sup>2</sup> )		Part no.
	Absorption	Emission	Gross	Net	
<b>Greenskies FKC-1S</b>					
Portrait	95 ± 2	12 ± 2	2.37	2.23	<b>7 747 025 748</b>
<b>Greenskies FKC-1W</b>					
Landscape	95 ± 2	12 ± 2	2.37	2.23	<b>7 747 025 749</b>
<b>Greenskies FKT-1S</b>					
Portrait	95 ± 2	5 ± 2	2.37	2.23	<b>7 747 025 750</b>
<b>Greenskies FKT-1W</b>					
Landscape	95 ± 2	5 ± 2	2.37	2.23	<b>7 747 025 751</b>

## Control options

Part no.	Description
7 739 300 378	TDS10 Solar Controller
<b>Intelligent controls</b>	
7 716 192 068*	ISM1 Intelligent Solar Module

\*Greenstar 30CDi System boiler fitted with optional diverter valve only and FR110 or FW100.

The Greenskies solar water heating system gives even more siting flexibility from portrait or landscape and in-roof or wall mounted options\*. The Greenskies range also includes a range of twin coiled cylinders.

**For more information refer to Solar Tech & Spec**

**Part number: 8 716 110 080** or visit

[www.worcester-bosch.co.uk](http://www.worcester-bosch.co.uk)

\*Wall mounted panels to be landscape only.

## Main components & accessories

(on roof installation)

Components	Part no.	Description
<b>Main components</b>		
	7 739 300 377	Solar pump station
	7 747 002 438	Connection set FS55 for FKC on roof
	7 739 300 331	Expansion vessel connector
	7 739 300 119	Expansion vessel 25L <sup>†</sup>
	7 739 300 120	Expansion vessel 35L <sup>†</sup>
	7 739 300 058	Solar fluid 10L <sup>**</sup>
	7 739 300 057	Solar fluid 25L <sup>**</sup>
	7 739 300 432	Air vent set ELT5 for FKC
<b>Accessories</b>		
	7 739 300 436	Roof connection FKA3 for tile/plain tile
	7 739 300 281	Slate/crown tile hook
	7 739 300 282	Additional crown tile hook

\*\*Subject to system design











<sup>†</sup>Subject to system volume

## Solar water heating panels

### Worcester Greenskies solar panel kits

FKC-1S standard 2 panel portrait kit on roof







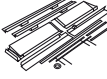

Part number: 7 716 150 000

Components	Part no.	Description
	7 747 025 748 x 2	Solar collector Worcester FKC-1S
	7 739 300 377	Solar pump station
	7 739 300 378	TDS10 solar controller
	7 739 300 441	On roof FKA6 portrait exten 1 coll
	7 739 300 057	Solar fluid 25L
	7 739 300 440	On roof FKA5 portrait basic 1 coll
	7 739 300 331	Expansion vessel connector
	7 747 002 438	Connection set FS55 for FKC on roof
	7 739 300 119	Expansion vessel 25L
	7 739 300 436 x 2	Roof connection FKA3 for tile/plain tile
	7 739 300 432	Air vent set ELT5 for FKC

### Worcester Greenskies solar panel kits

FKC-1S standard 2 panel portrait kit in roof

Part number: 7 716 150 001











Components	Part no.	Description
	7 747 025 748 x 2	Solar collector Worcester FKC-1S
	7 739 300 463	Roof integrated FKI5 portrait basic 2 coll tile
	7 739 300 377	Solar pump station
	7 739 300 378	TDS10 solar controller
	7 739 300 057	Solar fluid 25L
	7 739 300 331	Expansion vessel connector
	7 747 002 439	Connection set FS56 for FKC roof integrated
	7 739 300 119	Expansion vessel 25L
	7 739 300 432	Air vent set ELT5 for FKC

## Solar water heating panels

### Worcester Greenskies solar panel kits

FKC-1W standard 2 panel landscape kit on roof







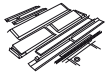

Part number: 7 716 150 002

Components	Part no.	Description
	7 747 025 749 x 2	Solar collector Worcester FKC-1W
	7 739 300 377	Solar pump station
	7 739 300 378	TDS10 solar controller
	7 739 300 443	On roof FKA8 landscape exten 1 coll
	7 739 300 057	Solar fluid 25L
	7 739 300 442	On roof FKA7 landscape basic 1 coll
	7 739 300 331	Expansion vessel connector
	7 747 002 438	Connection set FS55 for FKC on roof
	7 739 300 119	Expansion vessel 25L
	7 739 300 436 x 2	Roof connection FKA3 for tile/plain tile
	7 739 300 432	Air vent set ELT5 for FKC

### Worcester Greenskies solar panel kits

FKC-1W standard 2 panel landscape kit in roof







Part number: 7 716 150 003

Components	Part no.	Description
	7 747 025 749 x 2	Solar collector Worcester FKC-1W
	7 739 300 488	Roof integrated FKI11 landscape basic 2 coll tile
	7 739 300 377	Solar pump station
	7 739 300 378	TDS10 solar controller
	7 739 300 057	Solar fluid 25L
	7 739 300 331	Expansion vessel connector
	7 747 002 439	Connection set FS56 for FKC roof integrated
	7 739 300 119	Expansion vessel 25L
	7 739 300 432	Air vent set ELT5 for FKC







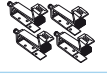

## Solar water heating panels

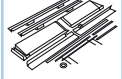
### Worcester Greenskies solar panel kits FKT-1S high 2 panel portrait kit on roof Part number: 7 716 150 004

Components	Part no.	Description
	7 747 025 750 x 2	Solar collector Worcester FKT-1S
	7 739 300 377	Solar pump station
	7 739 300 378	TDS10 solar controller
	7 739 300 441	On roof FKA6 portrait exten 1 coll
	7 739 300 057	Solar fluid 25L
	7 739 300 440	On roof FKA5 portrait basic 1 coll
	7 739 300 331	Expansion vessel connector
	7 747 002 442	Connection set FS59 for FKT on roof integrated
	7 739 300 119	Expansion vessel 25L
	7 739 300 436 x 2	Roof connection FKA3 for tile/plain tile
	7 739 300 433	Air vent set ELT6 for FKT

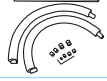
### Worcester Greenskies solar panel kits FKT-1S high 2 panel portrait kit in roof Part number: 7 716 150 005











Components	Part no.	Description
	7 747 025 750 x 2	Solar collector Worcester FKT-1S
	7 739 300 463	Roof integrated FKI5 portrait basic 2 coll tile
	7 739 300 377	Solar pump station
	7 739 300 378	TDS10 solar controller
	7 739 300 057	Solar fluid 25L
	7 739 300 331	Expansion vessel connector
	7 747 002 442	Connection set FS59 for FKT on roof integrated
	7 739 300 119	Expansion vessel 25L
	7 739 300 433	Air vent set ELT6 for FKT

## Solar water heating panels

### Worcester Greenskies solar panel kits

#### FKT-1W high 2 panel landscape kit on roof









Part number: 7 716 150 006

Components	Part no.	Description
	7 747 025 751 x 2	Solar collector Worcester FKT-1W
	7 739 300 377	Solar pump station
	7 739 300 378	TDS10 solar controller
	7 739 300 443	On roof FKA8 landscape exten 1 coll
	7 739 300 057	Solar fluid 25L
	7 739 300 442	On roof FKA7 landscape basic 1 coll
	7 739 300 331	Expansion vessel connector
	7 747 002 442	Connection set FS59 for FKT on roof integrated
	7 739 300 119	Expansion vessel 25L
	7 739 300 436 x 2	Roof connection FKA3 for tile/plain tile
	7 739 300 433	Air vent set ELT6 for FKT

### Worcester Greenskies solar panel kits

#### FKT-1W high 2 panel landscape kit in roof

Part number: 7 716 150 007

Components	Part no.	Description
	7 747 025 751 x 2	Solar collector Worcester FKT-1W
	7 739 300 488	Roof integrated FKI11 landscape basic 2 coll tile
	7 739 300 377	Solar pump station
	7 739 300 378	TDS10 solar controller
	7 739 300 057	Solar fluid 25L
	7 739 300 331	Expansion vessel connector
	7 747 002 442	Connection set FS59 for FKT on roof integrated
	7 739 300 119	Expansion vessel 25L
	7 739 300 433	Air vent set ELT6 for FKT

Solar water heating cylinders

# Greenskies Cylinder series

**Greenskies 180 Cylinder**    **Greenskies 210 Cylinder**

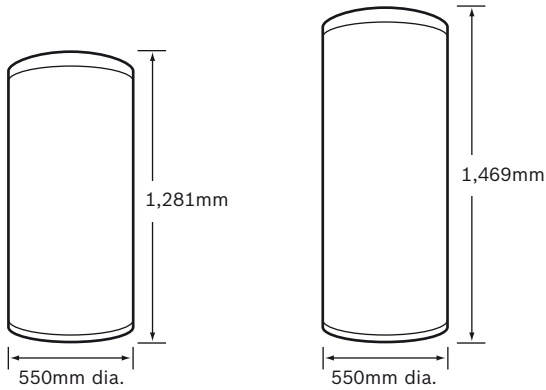

**Greenskies 250 Cylinder**    **Greenskies 300 Cylinder**

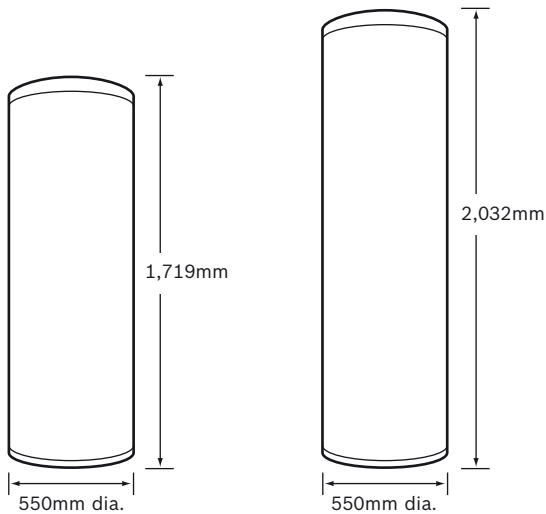

Volume domestic hot water (litres)	Dedicated solar volume (litres)	Weight full (kg)	Part no.
<b>Greenskies 180 Cylinder</b>			
180	55	230	<b>7 716 192 554</b>
<b>Greenskies 210 Cylinder</b>			
210	65	265	<b>7 716 192 555</b>
<b>Greenskies 250 Cylinder</b>			
250	75	310	<b>7 716 192 556</b>
<b>Greenskies 300 Cylinder</b>			
300	100	365	<b>7 716 192 557</b>

- Stainless steel cylinder (providing a 25 year guarantee\*)
- Unvented, providing mains pressure hot water
- Twin-coil for use with one fossil fuel appliance in addition to solar
- Comprehensive accessory and fittings pack
- WRAS and WRC-NSF approved
- Ozone depletion rate of zero
- Global warming potential of one



## The installer's choice for quality training.

Last year over 16,000 professional installers chose Worcester to meet their training needs.

- **Hands-on training for installation, commissioning and servicing of gas- and oil-fired boilers and renewable technologies, plus regulatory courses**
- **Superbly equipped training academies and regional training facilities strategically located throughout the country**
- **All tuition by experienced heating industry specialists.**

For full details call 01905 752526 or visit our website.

 **WORCESTER**  
Bosch Group

[www.worcester-bosch.co.uk](http://www.worcester-bosch.co.uk)

# Useful contacts



In partnership with  
Energy Saving Trust  
Tel: 020 7222 0101  
[www.energysavingtrust.org.uk](http://www.energysavingtrust.org.uk)



OFTEC  
Tel: 0845 65 85 080  
[www.oftec.org](http://www.oftec.org)



Institute of Plumbing and Heating Engineers  
Tel: 01708 472 791  
[www.ciphe.org.uk](http://www.ciphe.org.uk)



Gas Safe Register  
Tel: 0800 480 5500  
[www.gassaferegister.co.uk](http://www.gassaferegister.co.uk)



Association of Plumbing  
& Heating Contractors  
Tel: 02476 470 626  
[www.competentpersonsscheme.co.uk](http://www.competentpersonsscheme.co.uk)



Heating & Ventilation Contractors Association  
Tel: 0207 313 4900  
[www.hvca.org.uk](http://www.hvca.org.uk)



Heating and Hotwater Information Council  
Tel: 01926 430 486  
[www.centralheating.co.uk](http://www.centralheating.co.uk)



Benchmark  
Tel: 0845 600 2200



Society of British Gas Industries  
Tel: 01926 334 357  
[www.sbgi.org.uk](http://www.sbgi.org.uk)



British Standards Institution  
Tel: 0208 996 7070  
[www.bsigroup.co.uk](http://www.bsigroup.co.uk)



Worcester, Bosch Group  
Tel: 0844 892 9900  
[www.worcester-bosch.co.uk](http://www.worcester-bosch.co.uk)



Buderus Commercial  
Tel: 0844 892 3004  
[www.buderus.co.uk](http://www.buderus.co.uk)

## Other Bosch companies



**BOSCH**  
Invented for Life

Bosch Power Tools  
Tel: 01895 834 466  
[www.bosch-pt.co.uk](http://www.bosch-pt.co.uk)



**BOSCH**  
Invented for Life

Robert Bosch Domestic Appliances  
Tel: 01908 328 200  
[www.bosch-home.co.uk](http://www.bosch-home.co.uk)



**BOSCH**  
Invented for Life

Bosch Lawn & Garden  
Tel: 01449 742 000  
[www.bosch-pt.co.uk/gardentools](http://www.bosch-pt.co.uk/gardentools)



Blaupunkt  
Tel: 01895 838 880  
[www.blaupunkt.com/uk](http://www.blaupunkt.com/uk)



Bosch Car Services  
Tel: 01895 838 815  
[www.boschcarservice.co.uk](http://www.boschcarservice.co.uk)

# Metric & imperial measures

## Imperial to metric units

1 inch	= 25.4 mm	= 2.54 cm
1 foot	= 304.8 mm	= 0.3048 m
1 yard	= 914.4 mm	= 0.9144 m
1 mile	= 1609 m	= 1.609 km
1 square inch	= 645.2 mm <sup>2</sup>	= 6.452 cm <sup>2</sup>
1 square foot	= 929.0 cm <sup>2</sup>	
1 square yard	= 0.8361 m <sup>2</sup>	
1 acre	= 4047 m <sup>2</sup>	= 0.4047 ha
1 cubic inch	= 16387 mm <sup>3</sup>	= 0.016 39 dm <sup>3</sup>
1 cubic foot	= 0.02832 m <sup>3</sup>	= 28.3 dm <sup>3</sup>
1 cubic yard	= 0.764555 m <sup>3</sup>	
1 pint	= 0.5683 litre	= 568.3 ml
1 gallon	= 4.546 litre	= 4.546 kg water
1000 gallons	= 4.546 m <sup>3</sup>	
1 grain	= 0.06480 g	
1 ounce	= 28.35 g	
1 pound	= 453.6 g	= 0.4536 kg
1 ton	= 1016 kg	= 1.016 tonne
0.1 inches water gauge	= 0.25 mbar	
1.0 inch water gauge	= 2.5 mbar	
1 atmosphere	= 1.01325 bar	
1 British thermal unit	= 1055 J	
1 therm	= 105.5 MJ	
1000 Btu/h	= 0.2931 kW	= 1.055 MJ/h
1 horsepower	= 745.7 W	= 2.685 MJ/h
1 Btu/sft <sup>3</sup>	= 0.03796 MJ/m <sup>3</sup> (st)	
1 Btu/sft <sup>3</sup> (dry)	= 0.03723 MJ/m <sup>3</sup> (st)	
1 Btu/lb	= 2326 J/kg	

## Metric to imperial units

1 millimetre	= 0.03937 in		
1 metre	= 39.37 in	= 3.281 ft	= 1.094 yd
1 kilometre	= 0.6214 mile	= 1094 yd	
1 square millimetre	= 0.001550 in <sup>2</sup>		
1 square metre	= 1.196 yd <sup>2</sup>		
1 acre	= 119.6 yd <sup>2</sup>	= 0.0247 hectare	
1 hectare	= 11960 yd <sup>2</sup>	= 2.471 acre	
1 cubic millimetre	= 0.000061 in <sup>3</sup>		
1 cubic decimetre	= 61.02 in <sup>3</sup>	= 0.035 31 ft <sup>3</sup>	
1 cubic metre	= 35.31 ft <sup>3</sup>	= 1.308 yd <sup>3</sup>	= 220.0 gal
1 millilitre	= 0.001760 pint		
1 litre	= 1.760 pint	= 0.2200 gal	= 0.035 ft <sup>3</sup>
1 gram	= 0.03527 oz	= 15.43 grains	
1 kilogram	= 2.205 lb		
1 kilowatt	= 3412 Btu/h		

# Consumer and technical literature, CDs and DVDs

To order any of these items please phone 0844 892 9800 or you can download literature from **www.worcester-bosch.co.uk**

<b>Gas</b>	
	<b>Worcester Part No.</b>
<b>Consumer</b>	
Sales brochure, Greenstar Gas Products	8-716-109-642-0
Promotional brochure, Handy Hints	8-716-104-727-0
<b>Heating professional</b>	
Product guide, Gas-fired and Solar Thermal Heating Solutions	8-716-116-255
Tech & Spec, Greenstar Gas-fired System Range	8-716-115-775
Tech & Spec, Greenstar Gas-fired Regular Range	8-716-115-774
Tech & Spec, Greenstar Gas-fired Combi Range	8-716-115-773
Tech & Spec, Greenstar FS CDi Regular	8-716-115-422-0
Tech & Spec, Greenstar Highflow 440/550CDi	8-716-106-250-0
Tech & Spec, Pack, Greenstar Gas-fired Products	8-716-102-418-0

<b>Oil</b>	
	<b>Worcester Part No.</b>
<b>Consumer</b>	
Sales Brochure, Greenstar Oil-fired Products	8-716-110-393-0
<b>Heating professional</b>	
Product guide, Oil-fired and Solar Thermal Heating Solutions	8-716-116-256
Tech & Spec, Greenstar Danesmoor/Utility	8-716-110-391-0
Tech & Spec, Greenstar Heatslave	8-716-110-392-0
Tech & Spec, Greenstar Camray	8-716-113-356-0
Tech & Spec, Pack, Oil-fired Products	8-716-102-419-0

<b>Controls</b>	
	<b>Worcester Part No.</b>
<b>Worcester controls series</b>	
Technical & Specification Information	8-716-115-653

<b>Renewables</b>	
	<b>Worcester Part No.</b>
<b>Consumer</b>	
Combined Renewables Brochure	8-716-114-405-0
<b>Heating professional</b>	
Tech & Spec, Greenskies Solar	8-716-110-080-0
Tech & Spec, Greenstore Ground Source Heat Pumps	8-716-112-116-0
Tech & Spec, Greensource Air to Water Heat Pumps	8-716-115-319-0
Tech & Spec, Greensource Air to Air Heat Pump	8-716-115-438-0

<b>Training</b>	
	<b>Worcester Part No.</b>
<b>Heating professional</b>	
Training Pack - Information on Courses	8-716-112-218-0
Technical Bulletins	8-716-112-999-0

<b>Other</b>	
	<b>Worcester Part No.</b>
<b>Consumer</b>	
Brochure – Worcester Products & Services (Consumer)	8-716-112-666-0
<b>Heating professional</b>	
Brochure – Worcester Products & Services (Trade)	8-716-112-665-0

<b>Multimedia</b>	
	<b>Worcester Part No.</b>
<b>Consumer</b>	
Consumer DVD – Greenstar, Greenskies, Greenstore	8-716-112-668-0
<b>Heating professional</b>	
Heating Professional CD ROM – Greenstar, Greenskies, Greenstore	8-716-112-667-0
Technical CD ROM	8-716-104-960-0
Spares Catalogue	8-716-106-466-0
Greenstar CDi/i Junior Installation CD-ROM	8-716-112-251-0

# Notes



## Useful numbers

### Enquiries

Email: [service.mailbox@uk.bosch.com](mailto:service.mailbox@uk.bosch.com)  
or telephone 0844 892 3000

### Sales

Tel: 01905 752640 Fax: 01905 456445

### Spare Parts

Tel: 01905 752576 Fax: 01905 754620

### Technical Helpline (Pre & Post Sales)

Tel: 0844 892 3366 Fax: 01905 752741

### Renewables Technical Helpline

Email: [renewable.energy@uk.bosch.com](mailto:renewable.energy@uk.bosch.com)  
or telephone 0844 892 4010

### Training

Tel: 01905 752526 Fax: 01905 752535

### Literature

Email: [literature@uk.bosch.com](mailto:literature@uk.bosch.com) or download instantly  
from our website or telephone 0844 892 9800

Calls to the listed 0844 numbers are charged at up to 3 pence per minute from BT land lines.  
Calls from mobiles and some other networks may vary. Calls to and from Bosch  
Thermotechnology Ltd may be recorded for training and quality assurance purposes.

# [www.worcester-bosch.co.uk](http://www.worcester-bosch.co.uk)



In partnership with



energy saving trust™



**WORCESTER**  
Bosch Group

Worcester, Bosch Group,  
Cotswold Way, Warndon,  
Worcester, WR4 9SW

Worcester, Bosch Group is a brand name of Bosch Thermotechnology Ltd.

This leaflet is accurate at the date of printing, but may be superseded and should be disregarded if specification and/or appearances are changed in the interest of continued improvement. The statutory rights of the consumer are not affected.

Part No. 8 716 116 255 Issue A 12/10